



>> MODULAR UNITS AND SPECIAL SOLUTIONS

GFC worm gear sets consist of case-hardened and ground worm shafts combined with worm wheels made of high-quality, wear-resistant centrifugally cast or continuous cast bronze. Worm gear sets are characterised by shock-resistant, vibration-absorbing and low-noise gear teeth and provide large transmission ratios within a single stage. Self-locking at standstill is possible. We produce worm gear sets in standardised type ranges or according to the specifications of our customers. Sophisticated and individual solutions are provided by using modern and high-precision gear cutting machines and by continuously improving our technologies.



GFC

1



GFC worm gear sets with high efficiency and long service lifetime meet even the most extreme requirements in mechanical engineering.

1

Worm wheel sets

» **Design properties of GFC worm wheel sets:**

- >> worm shaft made of 16MnCrS5, case-hardened and ground
- >> splining according to DIN 3976, clockwise-ascending, (quality according to DIN 3974: worm shaft 6, worm wheel 7, others by request)

» **Requirements for the flawless function of GFC worm wheel sets:**

- >> correct tooth-bearing setting
- >> corresponding storage
- >> sufficient lubrication
- >> running-in has already been performed

For non-run-in worm shafts and worm wheels of the same type, we warrant full exchangeability. The only exceptions to this rule are worm wheel sets with a narrowed backlash. Such wheel sets are adjusted to the actual dimension of the housing-centre-point-distance and labeled in pairs.

The worm sets are operable in both rotation directions. Please enquire as to wheel sets with counterclockwise-ascending splining and custom splining.

Worm wheel sets 40 – 80

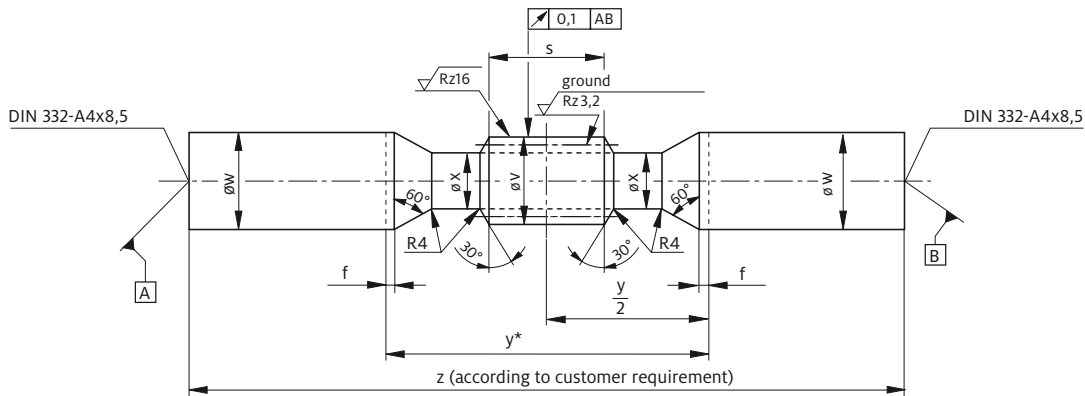

$\sqrt{Rz63}$ ($\sqrt{Rz16}$ $\sqrt{Rz3,2}$)

* measure for further processing

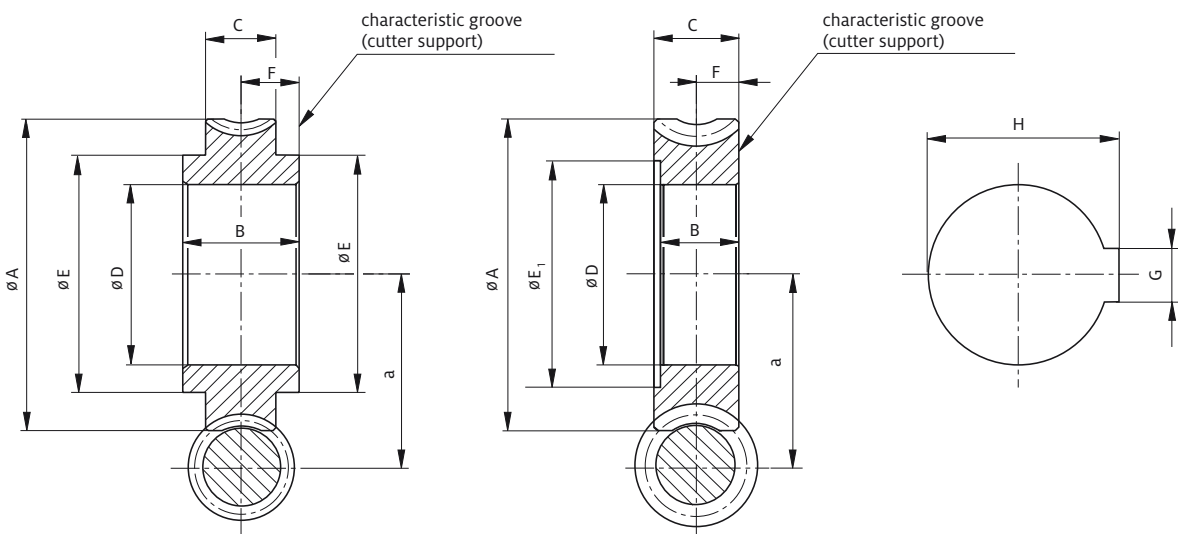
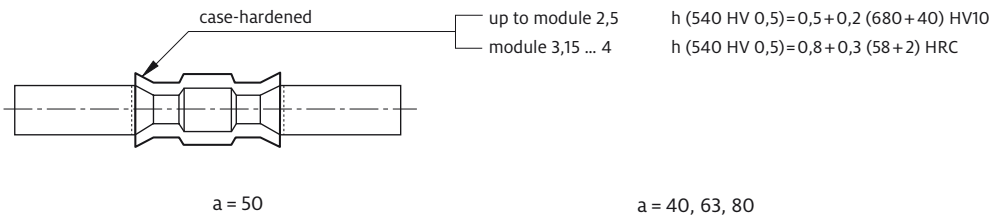

Shaft-centre distances a	Transmission ratio i_{1st}	Worm shaft							Worm wheel									
		v	s	x	w	y	f	z	A	B	C	D	E	E ₁	F	G	H	
								recommended value	-0.05									
									-0.10		H7							
40 ^{*1}	7.25-14.5-29	26.4	22	17	23	62	3	170	63.6	18.5	19	40	-	47	9.5	8	43.3	
	9.75-19.5-39	21.12	21	13.5	23	62	3	170	66.8	18.5	19	40	-	47	9.5	8	43.3	
	12.75-25.5-51	18.125	19	12	23	62	3	170	67.55	18.5	19	40	-	47	9.5	8	43.3	
	60	22	16	17	23	62	3	170	63	18.5	19	40	-	47	9.5	8	43.3	
	79	18.4	16	14	23	62	3	170	65.6	18.5	19	40	-	47	9.5	8	43.3	
50	4.83-7.25-14.5-29	31.5	32	20	26	83	3	180	81	35	24	55	73	-	17.5	10	57.4	
	9.5-19-38	26.4	29	17	26	83	3	180	83.6	35	21	55	73	-	17.5	10	57.4	
	12.5-25-50 ^{*1}	21.12	27	13.5	26	83	3	180	86.88	35	18	55	73	-	17.5	10	57.4	
	62	24.9	20	19	26	83	3	180	81.35	35	18	55	73	-	17.5	10	57.4	
	83	19	18	14	26	83	3	180	86	35	14	55	73	-	17.5	10	57.4	
63	4.83-7.25-14.5-29	39.8	41	25	28	101	3	200	102	27	27.5	62	-	68	13.5	18	66.4	
	9.75-19.5-39	31.5	37	20	28	101	3	200	107	27	27.5	62	-	68	13.5	18	66.4	
	12.75-25.5-51	26.4	32	17	28	101	3	200	109.6	27	27.5	62	-	68	13.5	18	66.4	
	61	31.2	25	23.5	28	101	3	200	102.8	27	27.5	62	-	68	13.5	18	66.4	
	82	24.9	23	19	28	101	3	200	107.4	27	27.5	62	-	68	13.5	18	66.4	
	106 ^{*1}	22	23	17	28	101	3	200	109	27	27.5	62	-	68	13.5	18	66.4	
80	5-7.5-15-30	48	50	30	34	134	5	240	132	32	32.5	80	-	90	16	18	84.4	
	10-20-40	39.8	45	25	34	134	5	240	136	32	32.5	80	-	90	16	18	84.4	
	13.25-26.5-53	31.5	40	20	34	134	5	240	141	32	32.5	80	-	90	16	18	84.4	
	62	39.5	32	30	34	134	5	240	130.5	32	32.5	80	-	90	16	18	84.4	
	82	31.2	29	23.5	34	134	5	240	136.8	32	32.5	80	-	90	16	18	84.4	
	110	24.9	26	19	34	134	5	240	141.4	32	32.5	80	-	90	16	18	84.4	

*1 Special toothing GFC 29343
Dimensions in mm / all rights reserved

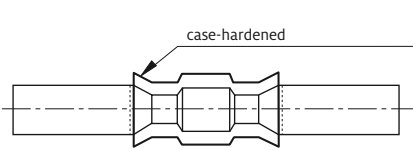
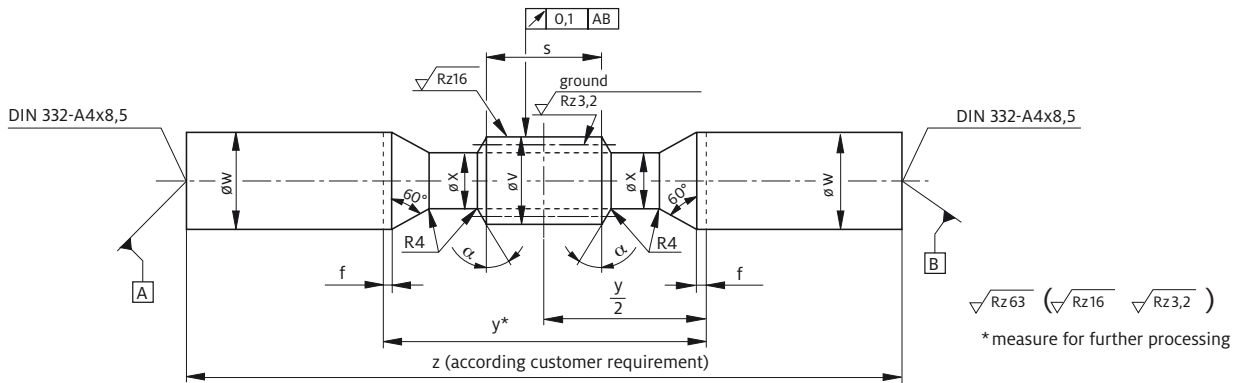

up to module 2,5	$h (540 \text{ HV } 0,5) = 0,5 + 0,2 (680 + 40) \text{ HV10}$
module 3,15 ... 10	$h (540 \text{ HV } 0,5) = 0,8 + 0,3 (58 + 2) \text{ HRC}$
module 12,5 ... 16	$h (540 \text{ HV } 0,5) = 1,2 + 0,3 (58 + 2) \text{ HRC}$

$\sqrt{Rz 63}$ ($\sqrt{Rz 16}$ $\sqrt{Rz 3,2}$)
 *measure for further processing

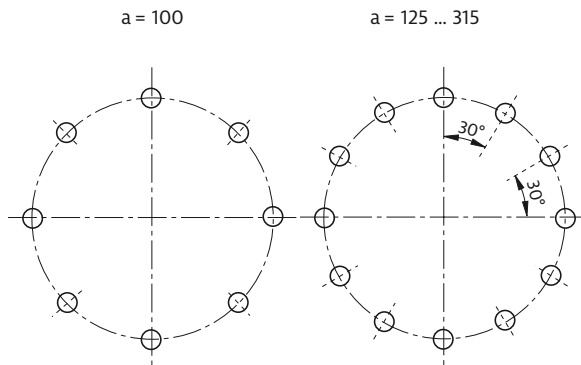
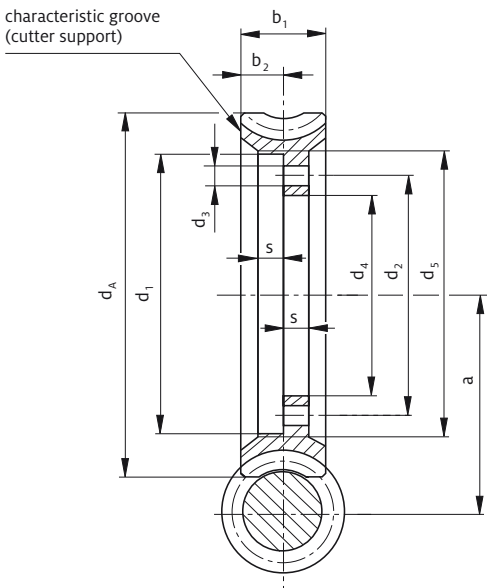

Assembly drawing

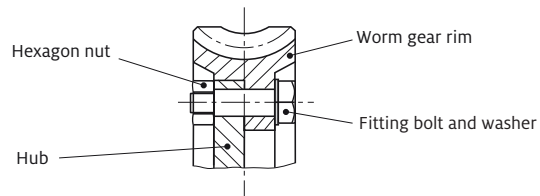

Secure the screw connection with a suitable glue.

Shaft-centre distances a	Transmission ratio i_{1st}	Worm shaft								Worm wheel									
		v	s	x	w	y	f	z	α	d_1	b_1	b_2	d_2	d_3	d_4	s	d_5	d_A	d_6
100	10-20-40	48	56	29	49	150	5	380	30°	135	32	16	115	10.8	90	8	133	172	139
	13-26-52	39.8	51	25	49	150	5	380	30°	145	27	13.5	125	10.8	100	8	143	176	149
	5-7.5-15-30	60	65	37	49	150	5	380	30°	120	40	20	105	10.8	80	12	123	165	130
	63	47.5	39	36	49	150	5	380	30°	135	32	16	115	10.8	90	8	133	165	139
	82	39.5	36	30	49	150	5	380	30°	145	27	13.5	125	10.8	100	8	143	170.5	149
	107	31.2	33	23	49	150	5	380	30°	145	27	13.5	125	10.8	100	8	143	176.8	149
125	10-20-40	60	65	37	54	185	5	420	30°	170	40	20	150	10.8	125	12	168	215	176
	13-26-52	48	63	29	54	185	5	420	30°	185	32	16	165	10.8	140	12	183	222	189
	7.25-14.5-29	75.6	80	47	54	185	5	420	30°	150	50	25	130	10.8	105	12	148	205.9	156
	62	59.3	49	44	54	185	5	420	30°	170	40	20	150	10.8	125	12	168	206.5	176
	83	47.5	45	35	54	185	5	420	30°	185	32	16	165	10.8	140	12	183	215	189
	107	39.5	42	30	54	185	5	420	30°	185	32	16	165	10.8	140	12	183	220.5	189
160	10-20-40	75.6	90	47	65	230	5	530	30°	220	50	25	195	12.8	165	16	215	275.9	225
	13.5-27-54	60	74	37	65	230	5	530	30°	240	40	20	215	12.8	185	14	235	285	245
	5-7.5-15-30	96	98	60	65	230	5	530	60°	195	64	32	170	12.8	140	16	190	264	200
	63	75	63	56	65	230	5	530	30°	220	50	25	195	12.8	165	16	215	265	225
	84	59.3	57	44	65	230	5	530	30°	240	40	20	215	12.8	185	14	235	276.4	245
	111	47.5	52	35	65	230	5	530	30°	240	40	20	215	12.8	185	14	235	285	245
200	10-20-40	96	112	60	77	280	5	630	60°	275	64	32	245	16.8	212	16	271	344	278
	13.25-26.5-53	75.6	102	47	77	280	5	630	30°	300	50	25	270	16.8	231	16	296	355.9	306
	7.5-15-30	115	122	70	77	280	5	630	60°	250	76	38	220	16.8	186	16	246	335	255
	63	95	82	72	77	280	5	630	30°	275	50	25	245	16.8	212	16	271	330	278
	83	75	82	56	77	280	5	630	30°	300	40	20	270	16.8	231	16	296	345	306
	110	59.3	82	44	77	280	5	630	30°	320	40	20	290	16.8	256	16	316	356.4	323
250	10-20-40	115	135	70	84	350	10	800	60°	350	76	38	320	16.8	286	20	346	435	353
	13-26-52	96	125	60	84	350	10	800	60°	375	64	32	345	16.8	310	20	371	444	378
	7.75-15.5-31	137	150	81	84	350	10	800	60°	320	90	45	290	16.8	256	20	316	425.5	323
	61	124.6	105	96	84	350	10	800	30°	350	76	38	320	16.8	286	20	346	406.9	353
	83	95	100	72	84	350	10	800	30°	375	60	30	345	16.8	310	20	371	430	378
	108	75	100	56	84	350	10	800	30°	390	60	30	360	16.8	327	20	386	444	393
315	10.25-20.5-41	137	185	81	100	420	10	960	60°	445	90	45	405	20.8	350	23	438	555.5	451
	13.25-26.5-53	115	165	70	100	420	10	960	60°	475	76	38	435	20.8	380	23	468	565	481
	15-30	172	210	101	100	420	10	960	60°	390	112	56	350	20.8	295	23	383	538	396
	60	156	160	120	100	420	10	960	60°	390	90	45	350	20.8	295	23	383	514	396
	82	124.6	125	96	100	420	10	960	30°	475	76	38	435	20.8	380	23	468	536.9	481
	109	95	125	72	100	420	10	960	30°	475	76	38	435	20.8	380	23	468	560	481

Indications regarding centre distances up to 500 mm on request

Dimensions in mm / All rights reserved.

*1 dowel screw DIN 610

To ensure the quickest possible and error-free handling of your order, we request from you the following complete specifications as to the following systematics:

