

# POWER WEDGE

## BELT CHARACTERISTICS

| section   | 3VX                       | 5VX | 8VX |
|---|---------------------------|-----|-----|
| a (mm)  | 9                         | 15  | 25  |
| s (mm)  | 8                         | 13  | 23  |
| external length - pitch length<br>= $\Delta_s$ (mm) | 5                         | 9   | 15  |
| weight (gr/m)                                       | 77                        | 207 | 569 |
| min. pulley diam. (mm)                              | 50                        | 170 | 315 |
| working temperature                                 | -30°C ÷ +90°C             |     |     |
| relevant standards                                  | RMA/MPTA IP22             |     |     |
| materials   | CR blend - polyester cord |     |     |

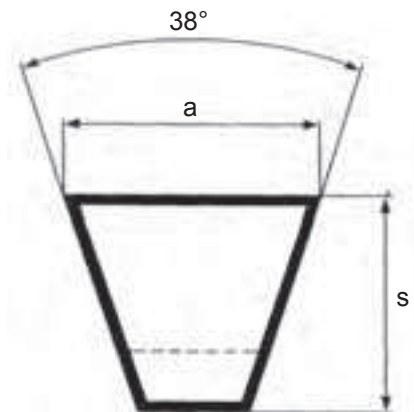

**TABLE 3 - CORRECTION FACTOR  $C_L$  according to type and length of the belt**

|     | 630  | 850  | 1150 | 1525 | 2030 | 2540 | 3810 | 5080 |
|-----|------|------|------|------|------|------|------|------|
| 3VX | 0,83 | 0,88 | 0,94 | 0,99 | 1,04 | 1,09 | 1,17 |      |
| 5VX |      |      | 0,83 | 0,87 | 0,93 | 0,97 | 1,03 | 1,08 |
| 8VX |      |      |      |      |      | 0,87 | 0,93 | 0,97 |

**TABLE 5 - INSTALLATION AND TAKE UP ALLOWANCE**

| L (mm)       | Y (mm) |     |     | X (mm) |
|--------------|--------|-----|-----|--------|
|              | 3VX    | 5VX | 8VX |        |
| 635 ÷ 1145   | 15     |     |     | 25     |
| 1205 ÷ 3555  | 20     | 25  | 40  | 55     |
| 3810 ÷ 5080  |        | 25  | 45  | 65     |
| 5385 ÷ 6350  |        | 35  | 45  | 105    |
| 6730 ÷ 9000  |        | 35  | 50  | 105    |
| 9500 ÷ 12700 |        |     | 50  | 140    |





**3VX SECTION**

| Code    | External length L <sub>e</sub> (mm) | Code    | External length L <sub>e</sub> (mm) | Code    | External length L <sub>e</sub> (mm) | Code    | External length L <sub>e</sub> (mm) | Code    | External length L <sub>e</sub> (mm) | Code    | External length L <sub>e</sub> (mm) | Code     | External length L <sub>e</sub> (mm) |
|---------|-------------------------------------|---------|-------------------------------------|---------|-------------------------------------|---------|-------------------------------------|---------|-------------------------------------|---------|-------------------------------------|----------|-------------------------------------|
| 3VX 250 | 630                                 | 3VX 315 | 800                                 | 3VX 400 | 1015                                | 3VX 500 | 1270                                | 3VX 630 | 1600                                | 3VX 800 | 2030                                | 3VX 1000 | 2540                                |
| 3VX 265 | 670                                 | 3VX 335 | 850                                 | 3VX 425 | 1080                                | 3VX 530 | 1345                                | 3VX 670 | 1700                                | 3VX 850 | 2160                                | 3VX 1060 | 2690                                |
| 3VX 280 | 710                                 | 3VX 355 | 900                                 | 3VX 450 | 1145                                | 3VX 560 | 1420                                | 3VX 710 | 1800                                | 3VX 900 | 2290                                | 3VX 1120 | 2840                                |
| 3VX 300 | 760                                 | 3VX 375 | 950                                 | 3VX 475 | 1205                                | 3VX 600 | 1525                                | 3VX 750 | 1900                                | 3VX 950 | 2410                                | 3VX 1180 | 3000                                |
|         |                                     |         |                                     |         |                                     |         |                                     |         |                                     |         |                                     | 3VX 1250 | 3180                                |
|         |                                     |         |                                     |         |                                     |         |                                     |         |                                     |         |                                     | 3VX 1320 | 3350                                |
|         |                                     |         |                                     |         |                                     |         |                                     |         |                                     |         |                                     | 3VX 1400 | 3550                                |
|         |                                     |         |                                     |         |                                     |         |                                     |         |                                     |         |                                     | 3VX 1500 | 3810                                |

**TABLE 4 - P<sub>b</sub> (kW) referred to d (mm)**

| RPM  | 56   | 60   | 63   | 67   | 71   | 80   | 90   | 100  | 112   | 125    | 132    | 140    |
|------|------|------|------|------|------|------|------|------|-------|--------|--------|--------|
| 100  | 0,10 | 0,12 | 0,13 | 0,14 | 0,16 | 0,19 | 0,23 | 0,27 | 0,32  | 0,37   | 0,39   | 0,43   |
| 200  | 0,19 | 0,22 | 0,24 | 0,27 | 0,30 | 0,37 | 0,44 | 0,52 | 0,61  | 0,70   | 0,75   | 0,81   |
| 500  | 0,41 | 0,48 | 0,54 | 0,61 | 0,68 | 0,84 | 1,02 | 1,20 | 1,41  | 1,64   | 1,76   | 1,90   |
| 700  | 0,55 | 0,65 | 0,72 | 0,82 | 0,92 | 1,14 | 1,39 | 1,63 | 1,92  | 2,23   | 2,40   | 2,58   |
| 900  | 0,68 | 0,81 | 0,90 | 1,03 | 1,15 | 1,43 | 1,74 | 2,05 | 2,41  | 2,80   | 3,01   | 3,25   |
| 1000 | 0,74 | 0,88 | 0,99 | 1,13 | 1,26 | 1,57 | 1,91 | 2,25 | 2,65  | 3,09   | 3,32   | 3,58   |
| 1400 | 0,99 | 1,18 | 1,32 | 1,51 | 1,70 | 2,12 | 2,59 | 3,05 | 3,59  | 4,18   | 4,49   | 4,85   |
| 1500 | 1,04 | 1,25 | 1,40 | 1,60 | 1,80 | 2,25 | 2,75 | 3,24 | 3,82  | 4,45   | 4,78   | 5,16   |
| 1700 | 1,16 | 1,39 | 1,56 | 1,78 | 2,01 | 2,52 | 3,07 | 3,62 | 4,27  | 4,97   | 5,34   | 5,76   |
| 1800 | 1,21 | 1,45 | 1,64 | 1,87 | 2,11 | 2,64 | 3,23 | 3,81 | 4,49  | 5,22   | 5,61   | 6,05   |
| 2500 | 1,58 | 1,91 | 2,15 | 2,47 | 2,79 | 3,51 | 4,29 | 5,06 | 5,97  | 6,93   | 7,43   | 8,00   |
| 2900 | 1,78 | 2,15 | 2,43 | 2,80 | 3,16 | 3,97 | 4,86 | 5,73 | 6,75  | 7,82   | 8,39   | 9,02   |
| 3000 | 1,82 | 2,21 | 2,49 | 2,87 | 3,25 | 4,09 | 5,00 | 5,89 | 6,94  | 8,04   | 8,62   | 9,26   |
| 3500 | 2,05 | 2,49 | 2,82 | 3,25 | 3,68 | 4,63 | 5,67 | 6,67 | 7,84  | 9,06   | 9,69   | 10,39  |
| 3600 | 2,09 | 2,55 | 2,88 | 3,32 | 3,76 | 4,74 | 5,79 | 6,82 | 8,01  | 9,25   | 9,89   | 10,60  |
| 4000 | 2,26 | 2,76 | 3,12 | 3,61 | 4,09 | 5,15 | 6,29 | 7,39 | 8,67  | 9,97   | 10,65  | 11,39  |
| 4500 | 2,46 | 3,00 | 3,41 | 3,94 | 4,46 | 5,62 | 6,86 | 8,05 | 9,41  | 10,78  | 11,47* | 12,23* |
| 5000 | 2,64 | 3,23 | 3,67 | 4,25 | 4,81 | 6,06 | 7,39 | 8,64 | 10,06 | 11,46* | 12,15* |        |

**P<sub>d</sub> (kW) referred to i**

| RPM  | i    | 1,00±1,01 | 1,02±1,05 | 1,06±1,26 | 1,27±1,57 | over 1,57 |
|------|------|-----------|-----------|-----------|-----------|-----------|
| 100  | 0,00 | 0,00      | 0,01      | 0,01      | 0,01      | 0,01      |
| 200  | 0,00 | 0,00      | 0,02      | 0,02      | 0,02      | 0,03      |
| 500  | 0,00 | 0,01      | 0,04      | 0,06      | 0,07      | 0,07      |
| 700  | 0,00 | 0,01      | 0,06      | 0,08      | 0,10      | 0,10      |
| 900  | 0,00 | 0,01      | 0,07      | 0,10      | 0,12      | 0,12      |
| 1000 | 0,00 | 0,01      | 0,08      | 0,11      | 0,14      | 0,14      |
| 1400 | 0,00 | 0,02      | 0,11      | 0,16      | 0,19      | 0,19      |
| 1500 | 0,00 | 0,02      | 0,12      | 0,17      | 0,21      | 0,21      |
| 1700 | 0,00 | 0,02      | 0,14      | 0,19      | 0,24      | 0,24      |
| 1800 | 0,00 | 0,02      | 0,14      | 0,21      | 0,25      | 0,25      |
| 2500 | 0,00 | 0,03      | 0,20      | 0,29      | 0,35      | 0,35      |
| 2900 | 0,00 | 0,04      | 0,23      | 0,33      | 0,40      | 0,40      |
| 3000 | 0,00 | 0,04      | 0,24      | 0,34      | 0,42      | 0,42      |
| 3500 | 0,00 | 0,04      | 0,28      | 0,40      | 0,49      | 0,49      |
| 3600 | 0,00 | 0,04      | 0,29      | 0,41      | 0,50      | 0,50      |
| 4000 | 0,00 | 0,05      | 0,32      | 0,46      | 0,55      | 0,55      |
| 4500 | 0,00 | 0,06      | 0,36      | 0,52      | 0,62      | 0,62      |
| 5000 | 0,00 | 0,06      | 0,40      | 0,57      | 0,69      | 0,69      |

**High strength cords**

Carry high power loads with minimum stretch. Better belt stability. Fewer take-up adjustments.

**Fabric laminates**

Located in the "power zone" to maximize benefits. Provide controlled response to shock loads.

**Raw edge sidewalls**

Greater contact with the pulley surface produces a smoother running belt. Keep a tighter grip to reduce slippage, improve performance and efficiency.

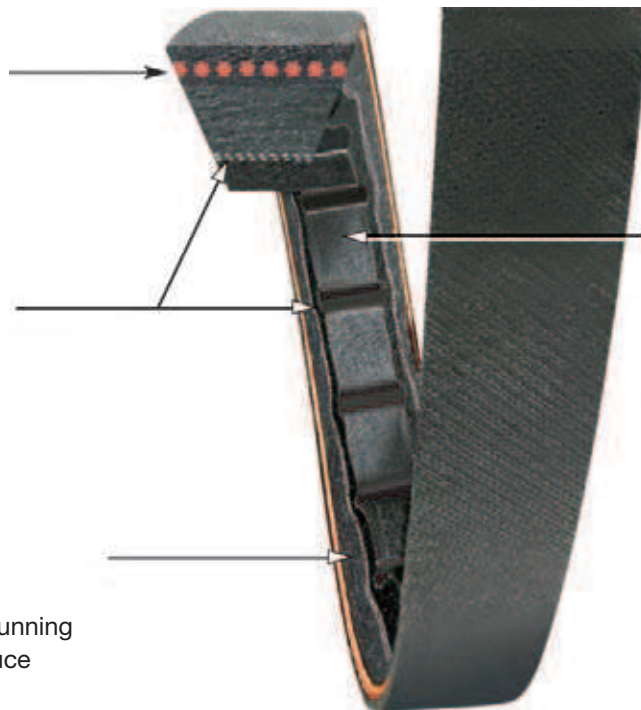

**Precision molded cogs**

Improve belt flexibility and reduce bending stress. Help dissipating heat assuring longer life.

\* Belt speed is greater than 30 m/s then is necessary to use dynamically balanced pulleys. A reduction in belt life can be expected. Suggested a smaller section.

# POWER WEDGE



## 5VX SECTION

| Code    | External length L <sub>e</sub> (mm) | Code    | External length L <sub>e</sub> (mm) | Code    | External length L <sub>e</sub> (mm) | Code    | External length L <sub>e</sub> (mm) | Code    | External length L <sub>e</sub> (mm) | Code    | External length L <sub>e</sub> (mm) | Code     | External length L <sub>e</sub> (mm) | Code     | External length L <sub>e</sub> (mm) |
|---------|-------------------------------------|---------|-------------------------------------|---------|-------------------------------------|---------|-------------------------------------|---------|-------------------------------------|---------|-------------------------------------|----------|-------------------------------------|----------|-------------------------------------|
| 5VX 450 | 1150                                | 5VX 540 | 1370                                | 5VX 600 | 1525                                | 5VX 680 | 1730                                | 5VX 780 | 1980                                | 5VX 860 | 2180                                | 5VX 1000 | 2540                                | 5VX 1160 | 2950                                |
| 5VX 470 | 1190                                | 5VX 550 | 1400                                | 5VX 610 | 1550                                | 5VX 690 | 1750                                | 5VX 800 | 2030                                | 5VX 880 | 2240                                | 5VX 1030 | 2620                                | 5VX 1180 | 3000                                |
| 5VX 490 | 1250                                | 5VX 560 | 1420                                | 5VX 630 | 1600                                | 5VX 710 | 1800                                | 5VX 810 | 2060                                | 5VX 900 | 2290                                | 5VX 1060 | 2690                                | 5VX 1230 | 3130                                |
| 5VX 500 | 1270                                | 5VX 570 | 1450                                | 5VX 650 | 1650                                | 5VX 730 | 1850                                | 5VX 830 | 2110                                | 5VX 930 | 2360                                | 5VX 1080 | 2740                                | 5VX 1250 | 3180                                |
| 5VX 510 | 1290                                | 5VX 580 | 1470                                | 5VX 660 | 1680                                | 5VX 740 | 1880                                | 5VX 840 | 2130                                | 5VX 950 | 2410                                | 5VX 1120 | 2840                                | 5VX 1320 | 3350                                |
| 5VX 530 | 1345                                | 5VX 590 | 1500                                | 5VX 670 | 1700                                | 5VX 750 | 1900                                | 5VX 850 | 2160                                | 5VX 960 | 2440                                | 5VX 1150 | 2920                                | 5VX 1400 | 3550                                |
|         |                                     |         |                                     |         |                                     |         |                                     |         |                                     |         |                                     |          |                                     | 5VX 1500 | 3810                                |
|         |                                     |         |                                     |         |                                     |         |                                     |         |                                     |         |                                     |          |                                     | 5VX 1600 | 4060                                |
|         |                                     |         |                                     |         |                                     |         |                                     |         |                                     |         |                                     |          |                                     | 5VX 1700 | 4320                                |
|         |                                     |         |                                     |         |                                     |         |                                     |         |                                     |         |                                     |          |                                     | 5VX 1800 | 4570                                |
|         |                                     |         |                                     |         |                                     |         |                                     |         |                                     |         |                                     |          |                                     | 5VX 1900 | 4830                                |
|         |                                     |         |                                     |         |                                     |         |                                     |         |                                     |         |                                     |          |                                     | 5VX 2000 | 5080                                |

**TABLE 4 - P<sub>b</sub> (kW) referred to d (mm)**

| RPM  | mm | 112   | 118    | 125    | 132    | 140    | 160    | 180    | 200    | 224    | 250    | 265    | 280   |
|------|----|-------|--------|--------|--------|--------|--------|--------|--------|--------|--------|--------|-------|
| 100  |    | 0,57  | 0,63   | 0,70   | 0,77   | 0,85   | 1,06   | 1,26   | 1,46   | 1,70   | 1,95   | 2,10   | 2,25  |
| 200  |    | 1,04  | 1,16   | 1,30   | 1,44   | 1,60   | 1,99   | 2,37   | 2,76   | 3,22   | 3,71   | 3,99   | 4,27  |
| 500  |    | 2,32  | 2,60   | 2,93   | 3,25   | 3,63   | 4,55   | 5,46   | 6,37   | 7,44   | 8,60   | 9,27   | 9,93  |
| 700  |    | 3,10  | 3,48   | 3,93   | 4,38   | 4,88   | 6,14   | 7,39   | 8,63   | 10,09  | 11,67  | 12,57  | 13,47 |
| 900  |    | 3,84  | 4,32   | 4,89   | 5,45   | 6,09   | 7,68   | 9,24   | 10,80  | 12,64  | 14,61  | 15,74  | 16,85 |
| 1000 |    | 4,19  | 4,73   | 5,35   | 5,97   | 6,67   | 8,42   | 10,15  | 11,85  | 13,88  | 16,04  | 17,27  | 18,49 |
| 1400 |    | 5,54  | 6,27   | 7,12   | 7,96   | 8,91   | 11,28  | 13,60  | 15,89  | 18,59  | 21,45  | 23,07  | 24,66 |
| 1500 |    | 5,86  | 6,64   | 7,54   | 8,43   | 9,45   | 11,96  | 14,43  | 16,85  | 19,70  | 22,72  | 24,42  | 26,10 |
| 1700 |    | 6,48  | 7,35   | 8,36   | 9,36   | 10,49  | 13,29  | 16,03  | 18,72  | 21,86  | 25,17  | 27,03  | 28,85 |
| 1800 |    | 6,79  | 7,70   | 8,76   | 9,81   | 11,00  | 13,93  | 16,81  | 19,62  | 22,90  | 26,34  | 28,27  | 30,16 |
| 2500 |    | 8,73  | 9,94   | 11,34  | 12,73  | 14,29  | 18,11  | 21,79  | 25,33  | 29,37  | 33,48* | 35,72* |       |
| 2900 |    | 9,71  | 11,08  | 12,65  | 14,21  | 15,95  | 20,19  | 24,23  | 28,06* | 32,36* |        |        |       |
| 3000 |    | 9,94  | 11,35  | 12,96  | 14,55  | 16,34  | 20,68  | 24,79  | 28,68* |        |        |        |       |
| 3500 |    | 11,00 | 12,57  | 14,37  | 16,14  | 18,12  | 22,86  | 27,28* |        |        |        |        |       |
| 3600 |    | 11,19 | 12,79  | 14,63  | 16,43  | 18,45  | 23,25* | 27,71* |        |        |        |        |       |
| 4000 |    | 11,88 | 13,60  | 15,57  | 17,48  | 19,61  | 24,63* |        |        |        |        |        |       |
| 4500 |    | 12,59 | 14,43  | 16,52  | 18,54* | 20,77* |        |        |        |        |        |        |       |
| 5000 |    | 13,10 | 15,04* | 17,22* | 19,31* |        |        |        |        |        |        |        |       |

**P<sub>d</sub> (kW) referred to i**

| RPM  | i | 1,00±1,01 | 1,02±1,05 | 1,06±1,26 | 1,27±1,57 | over 1,57 |
|------|---|-----------|-----------|-----------|-----------|-----------|
| 100  |   | 0,00      | 0,01      | 0,04      | 0,06      | 0,07      |
| 200  |   | 0,00      | 0,01      | 0,08      | 0,11      | 0,14      |
| 500  |   | 0,00      | 0,03      | 0,20      | 0,28      | 0,34      |
| 700  |   | 0,00      | 0,04      | 0,27      | 0,39      | 0,47      |
| 900  |   | 0,00      | 0,05      | 0,35      | 0,50      | 0,61      |
| 1000 |   | 0,00      | 0,06      | 0,39      | 0,56      | 0,68      |
| 1400 |   | 0,00      | 0,09      | 0,55      | 0,78      | 0,95      |
| 1500 |   | 0,00      | 0,09      | 0,59      | 0,84      | 1,02      |
| 1700 |   | 0,00      | 0,10      | 0,66      | 0,95      | 1,15      |
| 1800 |   | 0,00      | 0,11      | 0,70      | 1,01      | 1,22      |
| 2500 |   | 0,00      | 0,15      | 0,98      | 1,40      | 1,69      |
| 2900 |   | 0,00      | 0,18      | 1,13      | 1,62      | 1,97      |
| 3000 |   | 0,00      | 0,18      | 1,17      | 1,68      | 2,03      |
| 3500 |   | 0,00      | 0,21      | 1,37      | 1,96      | 2,37      |
| 3600 |   | 0,00      | 0,22      | 1,40      | 2,02      | 2,44      |
| 4000 |   | 0,00      | 0,24      | 1,56      | 2,24      | 2,71      |
| 4500 |   | 0,00      | 0,27      | 1,76      | 2,52      | 3,05      |
| 5000 |   | 0,00      | 0,31      | 1,95      | 2,80      | 3,39      |



\* Belt speed is greater than 30 m/s then is necessary to use dynamically balanced pulleys. A reduction in belt life can be expected. Suggested a smaller section.



**8VX SECTION**

| Code     | External length L <sub>e</sub> (mm) | Code     | External length L <sub>e</sub> (mm) | Code     | External length L <sub>e</sub> (mm) | Code     | External length L <sub>e</sub> (mm) | Code     | External length L <sub>e</sub> (mm) | Code     | External length L <sub>e</sub> (mm) | Code     | External length L <sub>e</sub> (mm) | Code | External length L <sub>e</sub> (mm) |
|----------|-------------------------------------|----------|-------------------------------------|----------|-------------------------------------|----------|-------------------------------------|----------|-------------------------------------|----------|-------------------------------------|----------|-------------------------------------|------|-------------------------------------|
| 8VX 1000 | 2540                                | 8VX 1120 | 2840                                | 8VX 1250 | 3180                                | 8VX 1400 | 3550                                | 8VX 1600 | 4060                                | 8VX 1800 | 4570                                | 8VX 2000 | 5080                                |      |                                     |
| 8VX 1060 | 2690                                | 8VX 1180 | 3000                                | 8VX 1320 | 3350                                | 8VX 1500 | 3810                                | 8VX 1700 | 4320                                | 8VX 1900 | 4830                                |          |                                     |      |                                     |

**TABLE 4 - P<sub>d</sub> (kW) referred to d (mm)**

| RPM \ mm | 315   | 335   | 355   | 375   | 400   | 425   | 475   | 530   | 600   | 670   | 750   | 800   |
|----------|-------|-------|-------|-------|-------|-------|-------|-------|-------|-------|-------|-------|
| 50       | 2,48  | 2,75  | 3,03  | 3,31  | 3,65  | 3,99  | 4,67  | 5,42  | 6,36  | 7,3   | 8,36  | 9,01  |
| 100      | 4,61  | 5,15  | 5,68  | 6,22  | 6,88  | 7,55  | 8,86  | 10,29 | 12,11 | 13,9  | 15,93 | 17,19 |
| 150      | 6,64  | 7,44  | 8,22  | 9,01  | 9,98  | 10,96 | 12,88 | 14,99 | 17,64 | 20,28 | 23,25 | 25,09 |
| 200      | 8,61  | 9,64  | 10,68 | 11,72 | 13    | 14,28 | 16,83 | 19,59 | 23,07 | 26,51 | 30,4  | 32,8  |
| 300      | 12,3  | 13,82 | 15,34 | 16,85 | 18,73 | 20,59 | 24,3  | 28,31 | 33,34 | 38,29 | 43,85 | 47,26 |
| 400      | 15,81 | 17,81 | 19,79 | 21,77 | 24,21 | 26,64 | 31,44 | 36,63 | 43,1  | 49,42 | 56,45 | 60,73 |
| 500      | 19,18 | 21,63 | 24,06 | 26,48 | 29,48 | 32,45 | 38,27 | 44,56 | 52,33 | 59,83 | 68,08 | 73,03 |
| 600      | 22,41 | 25,3  | 28,17 | 31,01 | 34,52 | 37,99 | 44,79 | 52,05 | 60,93 | 69,41 | 78,55 | 83,94 |
| 750      | 27,1  | 30,64 | 34,13 | 37,59 | 41,83 | 45,99 | 54,08 | 62,59 | 72,8  | 82,25 | 92,04 | 97,57 |
| 900      | 31,49 | 35,62 | 39,68 | 43,67 | 48,56 | 53,31 | 62,44 | 71,85 | 82,78 | 92,44 |       |       |
| 1000     | 34,42 | 38,94 | 43,37 | 47,71 | 52,97 | 58,08 | 67,78 | 77,6  | 88,67 |       |       |       |
| 1200     | 38,81 | 43,9  | 48,83 | 53,61 | 59,35 | 64,82 | 74,89 | 84,55 |       |       |       |       |
| 1400     | 42,24 | 47,72 | 52,97 | 57,97 | 63,88 | 69,36 | 79    |       |       |       |       |       |
| 1500     | 44,1  | 49,78 | 55,17 | 60,26 | 66,17 | 71,59 |       |       |       |       |       |       |
| 1700     | 46,24 | 52,04 | 57,44 | 62,4  |       |       |       |       |       |       |       |       |
| 1800     | 47,19 | 53,01 | 58,35 |       |       |       |       |       |       |       |       |       |
| 1900     | 47,8  | 53,56 |       |       |       |       |       |       |       |       |       |       |
| 2000     | 48,01 |       |       |       |       |       |       |       |       |       |       |       |

**P<sub>d</sub> (kW) referred to i**

| RPM \ i | 1,00±1,01 | 1,02±1,05 | 1,06±1,26 | 1,27±1,57 | over 1,57 |
|---------|-----------|-----------|-----------|-----------|-----------|
| 50      | 0,00      | 0,01      | 0,03      | 0,05      | 0,06      |
| 100     | 0,00      | 0,01      | 0,07      | 0,10      | 0,12      |
| 150     | 0,00      | 0,01      | 0,10      | 0,15      | 0,18      |
| 200     | 0,00      | 0,02      | 0,14      | 0,20      | 0,25      |
| 300     | 0,00      | 0,03      | 0,21      | 0,30      | 0,37      |
| 400     | 0,00      | 0,04      | 0,28      | 0,41      | 0,49      |
| 500     | 0,00      | 0,06      | 0,35      | 0,51      | 0,61      |
| 600     | 0,00      | 0,07      | 0,42      | 0,61      | 0,74      |
| 750     | 0,00      | 0,08      | 0,53      | 0,76      | 0,92      |
| 900     | 0,00      | 0,10      | 0,64      | 0,91      | 1,10      |
| 1000    | 0,00      | 0,11      | 0,71      | 1,01      | 1,23      |
| 1200    | 0,00      | 0,13      | 0,85      | 1,22      | 1,47      |
| 1400    | 0,00      | 0,15      | 0,99      | 1,42      | 1,72      |
| 1500    | 0,00      | 0,17      | 1,06      | 1,52      | 1,84      |
| 1700    | 0,00      | 0,19      | 1,20      | 1,72      | 2,08      |
| 1800    | 0,00      | 0,20      | 1,27      | 1,82      | 2,21      |
| 1900    | 0,00      | 0,21      | 1,34      | 1,93      | 2,33      |
| 2000    | 0,00      | 0,22      | 1,41      | 2,03      | 2,45      |

